

Play Action®

Contoured Leisure Swing™**Building Instructions****Important!**

This product is intended for use only on properly installed PlayStar playsets. Before using this accessory refer to the complete safety guidelines provided with your original playset. To obtain a free copy visit www.playstarinc.com or call 1-888-752-9782.

Warning!

Lawn swings are designed for use by children over two years of age. Use by children under the age of two can result in entrapment between the seat and back area. Never place children in a rearward facing position or with legs between the seat and backrest because the child's body may pass through the opening causing entrapment of child's head. No more than three occupants should be allowed on this accessory at one time, with a maximum weight of 105 pounds for each occupant.

We're Here To Help!Call Toll Free **1-888-752-9782**

Customer Service: Monday - Friday, 8:00 A.M. to 5:00 P.M. C.S.T.

PS 7960

CONTENTS

TOOLS REQUIRED

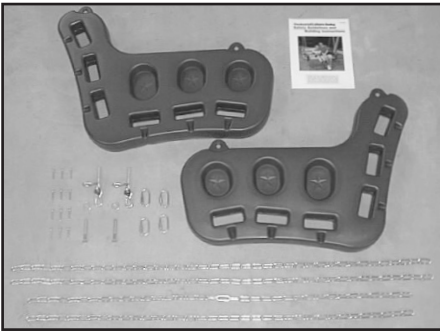

Contoured Leisure Swing Kit Contains:

- (2) Molded Sides
- (4) Welded-Link Chains
- (2) Swing Hangers
- Weather-Resistant Hardware
- Complete Illustrated Instructions

Socket Wrench
3/16" Socket
Adjustable Wrench
Ladder
Tape Measure
Safety Glasses
Drill

Square
Phillips Screwdriver
Saw
Hammer
1/8" & 1/4" Drill Bit
Pencil

HARDWARE INCLUDED (shown actual size)

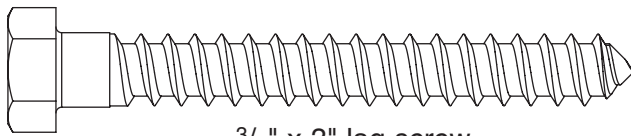

3/8" x 3" lag screw



#6 x 1 1/4" deck screw

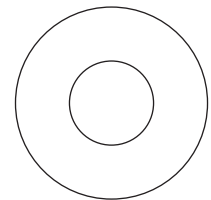

3/8" washer

CUTTING GUIDE

MEASURE, MARK AND IDENTIFY ALL LUMBER BEFORE CUTTING. (IF YOU DO NOT WISH TO MARK ON LUMBER, USE MASKING TAPE OR CHALK.) CUT ALL LUMBER BEFORE BEGINNING CONSTRUCTION.

2" x 4" x 8' – three (3) boards required

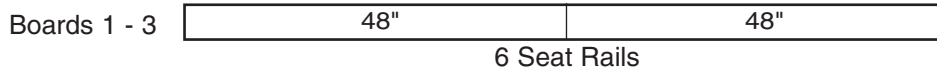

BUILDING INSTRUCTIONS

1. Insert the six 2" x 4" x 4' seat rails into the openings of one of the molded sides. (Fig. 1)
2. Adjust seat rails so there is a 1/2" overhang on the outside of the swing.
3. Repeat steps 1 and 2 for the other end.

Fig. 1

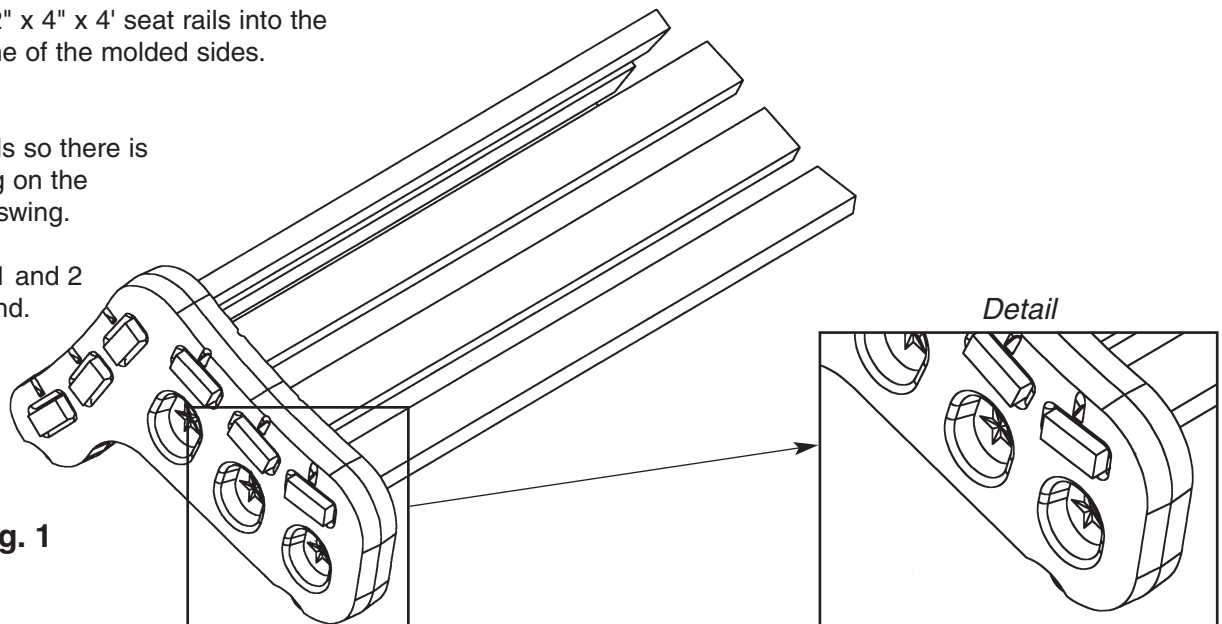

4. Drill a $\frac{1}{8}$ " pilot hole in the center of each seat rail on the inside edge of the molded side panel. **(Fig. 2A)**
5. Secure each seat rail with one #6 x $\frac{1}{4}$ " deck screw. **(Fig. 2B)**

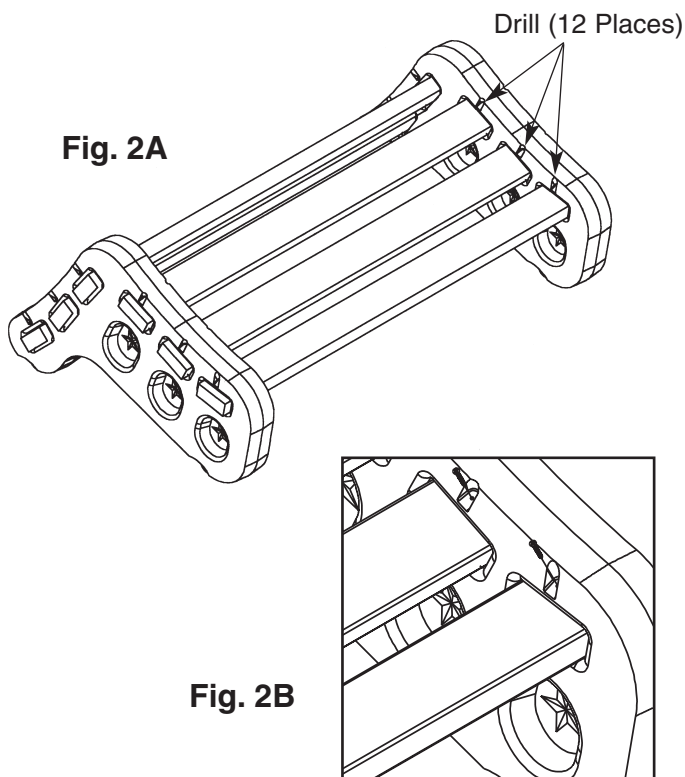

6. Attach one 40-link chain with a *quick link connector* to the front support of molded side panel. Attach one 36-link chain with a *quick link connector* to the back support of molded side panel. Tighten both *quick link connectors* with an adjustable wrench. **(Fig. 3)**
7. Repeat Step 6 for opposite side. **(Fig. 3)**
8. Lift the swing and hook the chains onto the swing hangers, attaching the back chains first.

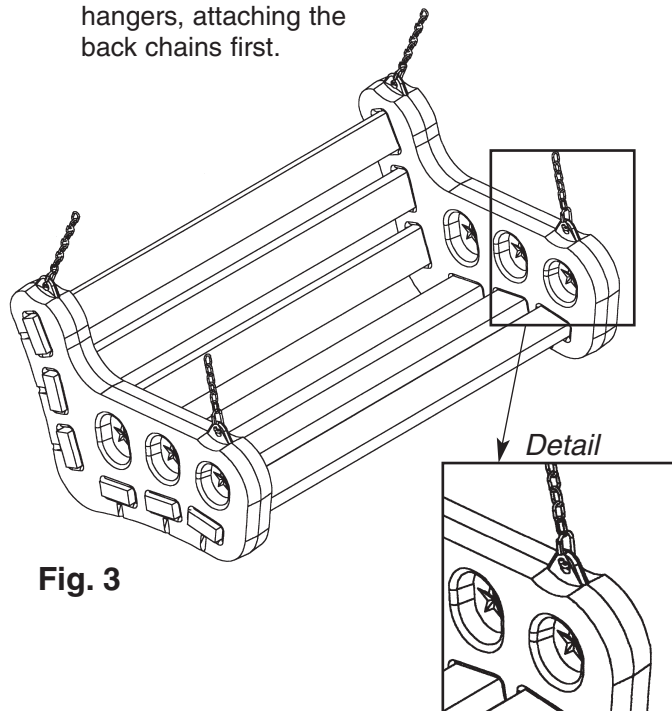

9. If you are adding the Contoured Leisure Swing to an existing PlayStar Play Action Set, the swing hangers are already in place. Hang swing from the two outermost hangers inside swing bay. **(Fig. 4A)**
10. If you do not have swing hangers in place, you will need to install them now.
11. Make two marks in one beam board 48" - 53" apart, centered between posts. **(Fig. 4A)**

Caution: The Contoured Leisure Swing must be at least 10" away from the closest point of all other rides or stationary objects.

12. Drill a $\frac{1}{4}$ " dia. hole $2\frac{1}{2}$ " deep in the center of each marked location. **(Fig. 4A)**
13. Screw swing hangers into beam by hand (a long screwdriver will help). Tighten swing hanger until loop is tight against adjoining beam and swing hanger is parallel with beam. **(Fig. 4B)**
14. Drill another $\frac{1}{4}$ " dia. hole $2\frac{1}{2}$ " deep in adjoining beam through swing hanger loop and secure each swing hanger with one $\frac{3}{8}$ " x 3" lag screw with washer. **(Fig. 4B)**

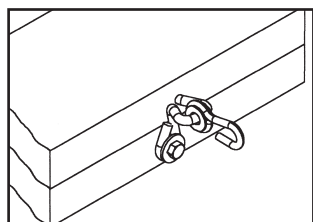
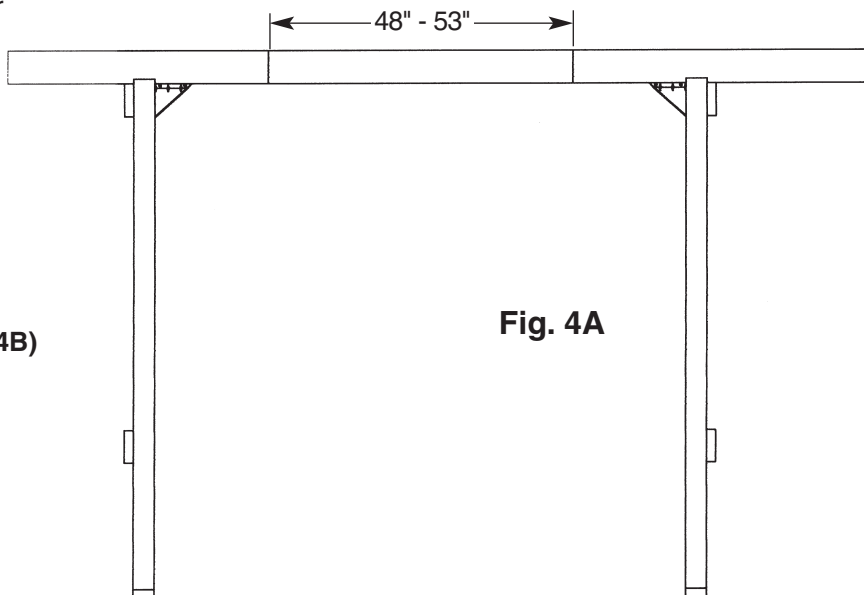

Fig. 4B

Fig. 4A

Thank You for choosing PlayStar's Play Action
Contoured Leisure Swing. Because it is our intention
to make this a positive family experience, we have
taken great care in preparing this product. Should
you have any questions, or if we can assist you in any
way, please call our friendly Customer Service
Department for immediate action.

Do not return to the store.
Please call us Toll Free at 1-888-PLAYSTAR
(752-9782)

Monday through Friday, 8:00 A.M. to 5:00 P.M. C.S.T.
Ask for Customer Service.

We Will Gladly Help!



PlayStar, Incorporated, Janesville, WI 53547